

Lifty DS



Application Instruction

Our products from the division BUILDING SOLUTIONS

SERVICES

- » On-site tests -> we ensure that your requirements are properly covered by our planning.
- » Test reports -> for your safety and documentation.
- » Trainings -> the knowledge of your employees from planning and production is enhanced by our experts on site, online or via webinar.
- » Planning support -> latest design software, planning documents, CAD data and much more can be downloaded any time from www.philipp-group.com.

HIGH DEMANDS ON PRODUCT SAFETY AND PRACTICALITY

- » Close cooperation with notified bodies and - if necessary - approval of our solutions.

TECHNICAL DEPARTMENT

- » Our expert-team will support you at any time during your planning phase with detailed advice.

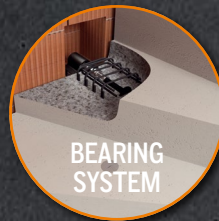
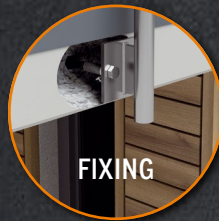

CONTENT

THE LIFTY DS	Page	4
Material	Page	4
Marking	Page	4
APPLICATION	Page	5
SAFETY / INSPECTION	Page	6
Safety advice	Page	6
Replacement criteria and inspection service	Page	6

THE PHILIPP LIFTY DS

The Lifty DS is part of the PHILIPP transport anchor system and complies with the VDI/ BV-BS-guideline "Lifting inserts and lifting systems for precast concrete elements" (VDI/ BV-BS 6205). The use of the Lifty DS requires the compliance with this Application Instruction, the Installation and Application Instruction of the particular threaded anchor as well as the General Installation Instruction. The Lifty DS is suitable for axial, diagonal and lateral tension.

TABLE 1: PERMISSIBLE LOAD BEARING CAPACITIES AND DIMENSIONS

Ref. no.	Type	perm. F 0° - 90° (kN)	Dimensions					Weight (kg/pc.)
			RD	h (mm)	e (mm)	h ₁ (mm)	Ø _s (mm)	
62LI12DS	RD 12	5.0	12	310	18	38	8	0.38
62LI16DS	RD 16	12.0	16	345	23	38	8	0.38
62LI20DS	RD 20	20.0	20	410	29	53	10	0.96
62LI24DS	RD 24	25.0	24	435	34	53	11	1.04
62LI30DS	RD 30	40.0	30	490	43	72	14	2.72
62LI36DS	RD 36	63.0	36	650	51	72	18	4.36
62LI42DS	RD 42	80.0	42	700	60	92	20	6.56
62LI52DS	RD 52	125.0	52	800	73	92	24	9.48

- The weight of 1.0 t corresponds to 10.0 kN.

MATERIAL

The Lifty DS consists of a forged ring bolt with a thread and a galvanised pressed-steel wire rope.

MARKING

The Lifty DS is labelled with a colour-coded tag. This label includes the following information:

- » Manufacturer (PHILIPP)
- » CE mark
- » Type (system / load class)
- » Maximum bearing capacity (e.g. 1,200 kg)
- » Year of manufacturing
- » Illustration of the permissible load direction

EC DECLARATION OF CONFORMITY (DOC)

The EC Declaration of Conformity (DoC) of the Lifty DS can be downloaded from our website www.philipp-group.com or is available on request.

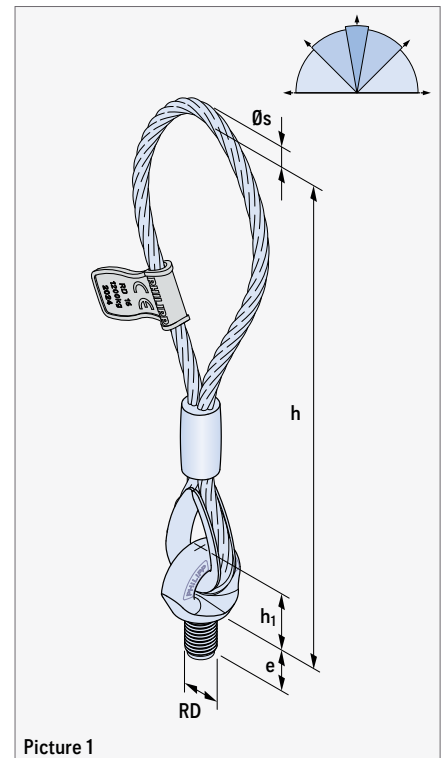

Picture 1

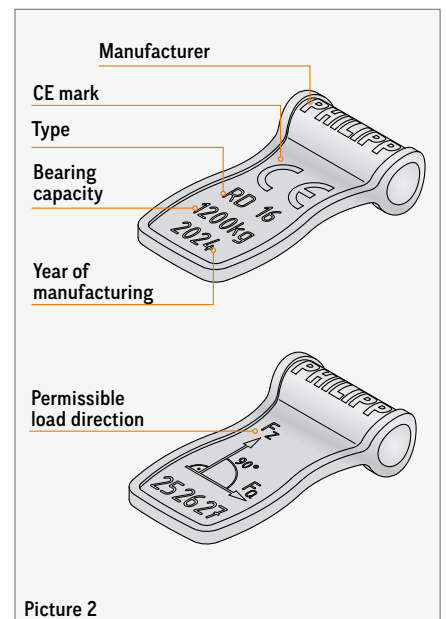

Picture 2

APPLICATION

The Lifty DS is a lifting device of the threaded transport anchor system and is supplied with a round thread (with metric pitch) or a metric thread. It must be screwed into the Threaded transport anchor tightly until the bottom part of the ringbolt has continuous pressure contact to the recess created before in the concrete unit. Therefore an optimal load transfer into the cast-in anchor is given, as the ring bolt is supported by the concrete in case of loading (picture 3). During rigging the loop of the Lifty DS must point to the tensile direction all the time. In order to align the Lifty DS into the correct position it is allowed to screw it back for half a turn at the most.

The Lifty DS can only be used with transport anchors installed recessed by one of the following recess formers:

KHN system:

- » Plastic: 72KHN12 - 72KHN52
- » Steel: 72KHN12STK - 72KHN52STK
- » Magnetic: 72MAXKHN12 - 72MAXKHN52

Nailing plate for diagonal tension system:

- » Plastic: 72KHN16-SZ15 - 72KHN52-SZ15
- » Steel: 72KHN16-SZ15ST - 72KHN52-SZ15ST

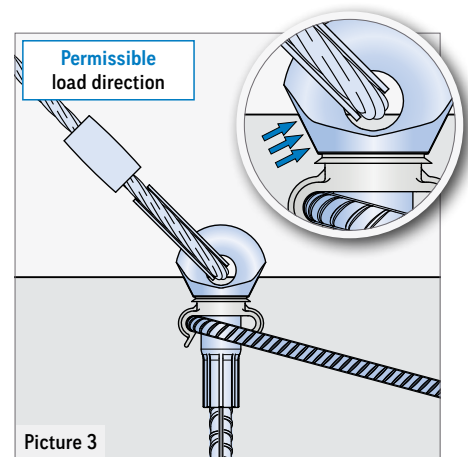

Picture 3

WARNING!
A use of inadmissible recess formers can lead to a reduction of the bearing capacity and to a failure of the Lifty DS or the transport anchor.

PLEASE NOTE!
Loading the Lifty DS right-angled to the ring bolt axis is inadmissible.



APPLICATION INSTRUCTION

The Application Instruction for the KHN system or the Installation and Application Instruction for the Recess former for diagonal tension system must be observed!



LOADING - ONLY IN TENSILE DIRECTION

Loading the Lifty DS is only admissible in the tensile direction of the ring bolt axis according to picture 4.

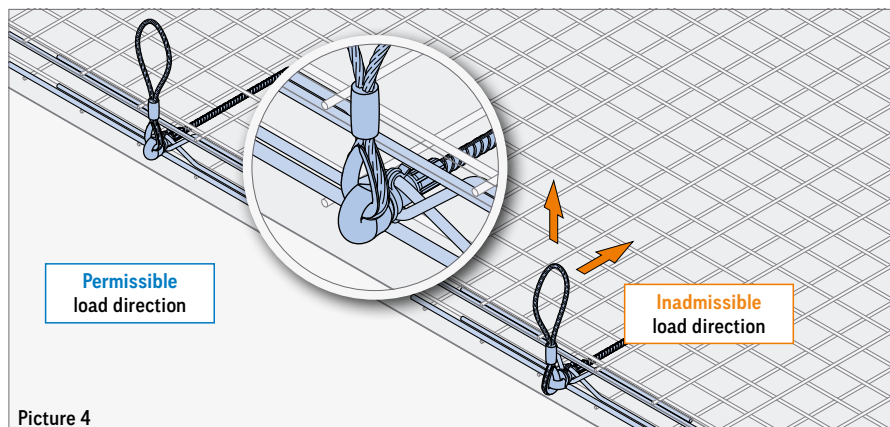

Picture 4

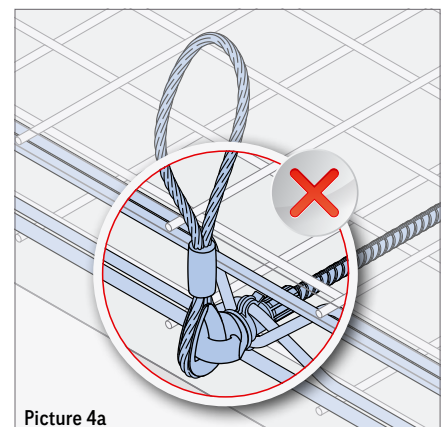

Picture 4a



USE OF ONLY ONE LIFTING DEVICE

Using only one Lifty DS in order to lift concrete elements attention must be paid that the Lifty is protected against unscrewing (e.g. by using a guy or guide rope at the concrete element).

REPLACEMENT CRITERIA AND INSPECTION

SAFETY NOTICE

As each other lifting equipment and lifting device the Lifty DS is subject to an annual inspection (acc. to the German DGUV regulation 109-017, para. 8.2). This inspection lies within the responsibility of the owner and has to be done by an expert. Depending on the working conditions inspections might be necessary in a shorter interval than once a year. This might be caused by frequent use, increased wear, corrosion or heat treatment.

In general, the current accident prevention regulations must be observed. The correct hook size and form should be considered in order to extend the durability.



WELDING

Welding or other strong heat influences on the Lifty DS are not allowed.



PLEASE NOTE!

The continued use of damaged lifting devices or equipment already met the discard criteria is not permitted!



ROUNDING RADIUS OF THE LOAD HOOKS

The rounding radius of the load hooks must be at least the rope diameter of the Lifty DS (picture 5). The use of too small, too large or sharp-edged hooks leads to a reduced lifetime of the lifting device (replacement criteria).

If the Lifty DS is loaded with extreme loads (e.g. by an event causing damage) which may have influenced the bearing capacity it must be examined extraordinarily by an expert. The criteria are given in section "Replacement criteria and inspection service".

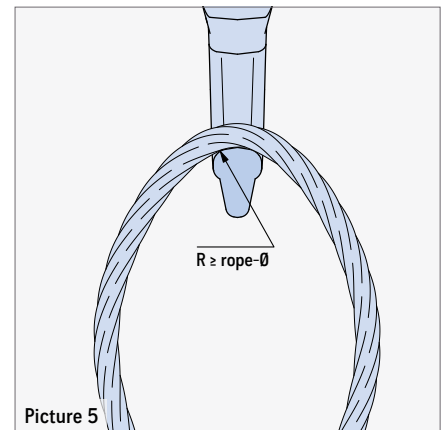

Picture 5

REPLACEMENT CRITERIA AND INSPECTION SERVICE

The replacement state of the Lifty DS follows the German regulation DGUV 109-017, para. 8.4. Prior inspection the Lifty DS must be cleaned. During inspection the following points have to be considered. If one is fulfilled the Lifty DS has reached its replacement state and must not be used anymore.

- » Broken strand
- » Kinks and bends
- » Loosening of external layer
- » Contusion in free lengths
- » Contusions in the support area of the eye with more than 4 broken wires
- » 4 broken wires on a length of the threefold of the wire rope diameter
- » 6 broken wires on a length of the sixfold of the wire rope diameter
- » 16 broken wires on a length of the thirtyfold of the wire rope diameter
- » Damaged or deformed wire rope connection or threaded area (e.g. twisted ring bolt)
- » Cracks or the capacity reducing corrosion pits
- » Unreadable or missing tag
- » Strongly deformed or missing thimble
- » Welding or other strong heat influences
- » Dropping below the permissible test dimensions (at the right)
- » Maximum service life: 15 years (see marking indication the year and month of production)

During the inspection of the ring bolt, the wear of the bolt diameter shall be checked. The replacement state for this part is reached when the forged ring bolt has a diminution of 10 % (picture 6 and table 2). The outer diameter of the thread must also be checked acc. to picture 6 and table 2.

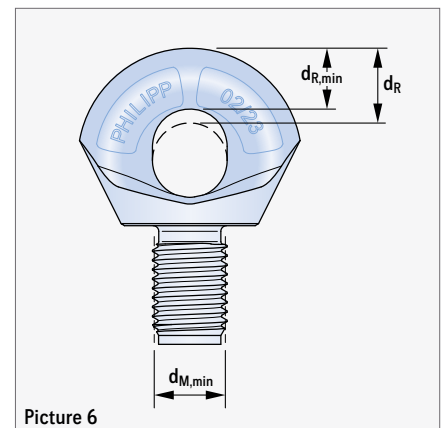

Picture 6

TABLE 2: TEST DIMENSIONS OF THE RING BOLT

Load class	$d_{M,min}$ (mm)	d_R (mm)	$d_{R,min}$ (mm)
12	11.50	16	14.4
16	15.45	16	14.4
20	19.40	22	19.8
24	23.40	22	19.8
30	29.40	32	28.8
36	35.40	32	28.8
42	41.20	39	35.1
52	51.20	39	35.1

NOTES

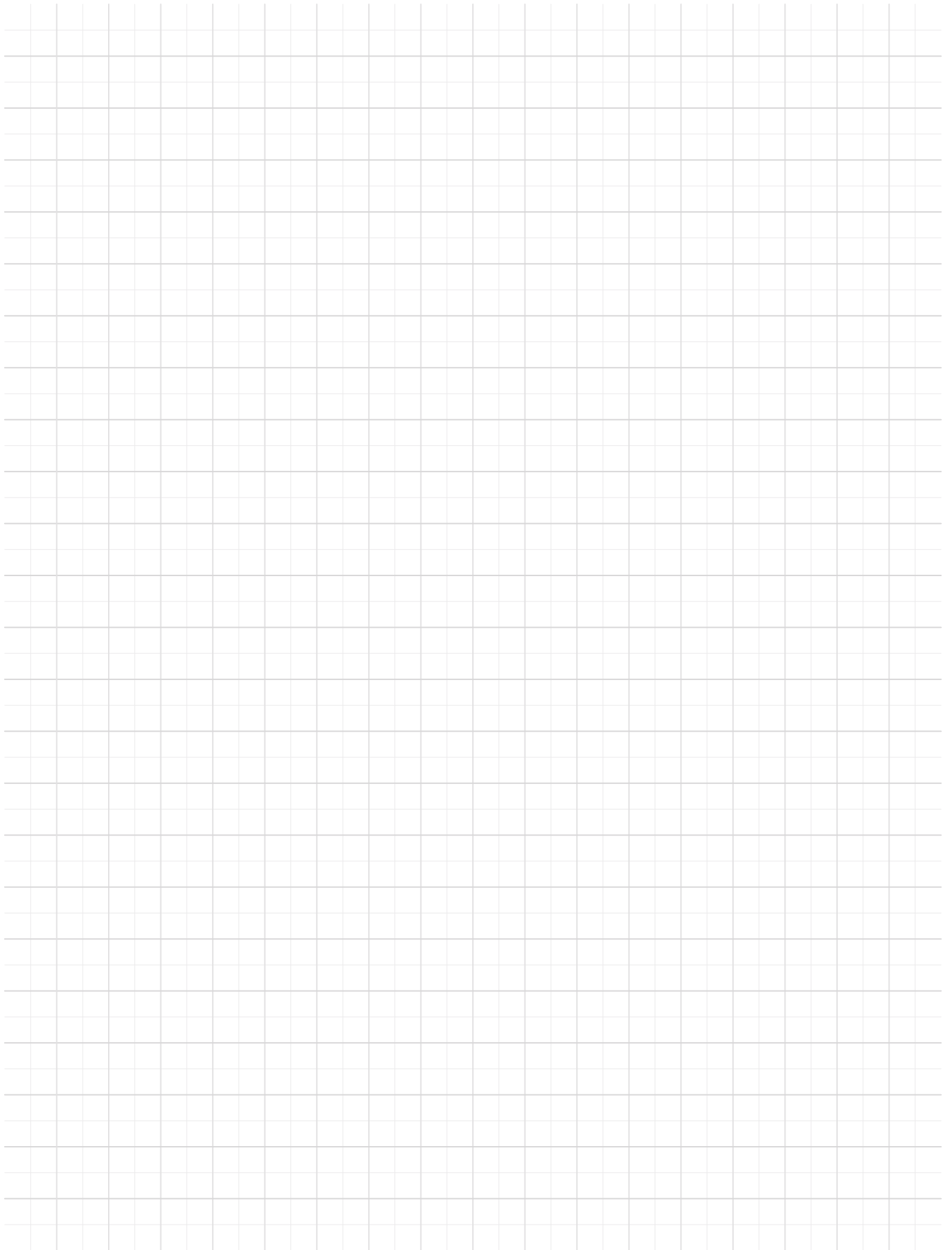

HEADQUARTERS

Lilienthalstraße 7-9
63741 Aschaffenburg

☎ +49 6021 40 27-0

✉ info@philipp-gruppe.de

PRODUCTION AND LOGISTICS

Hauptstraße 204
63814 Mainaschaff

☎ +49 6021 40 27-0

✉ info@philipp-gruppe.de

OFFICE COSWIG

Roßlauer Straße 70
06869 Coswig /Anhalt

☎ +49 34903 6 94-0

✉ info@philipp-gruppe.de

OFFICE NEUSS

Sperberweg 37
41468 Neuss

☎ +49 2131 3 59 18-0

✉ info@philipp-gruppe.de

OFFICE TANNHEIM

Robert-Bosch-Weg 12
88459 Tannheim /Allgäu

☎ +49 8395 8 13 35-0

✉ info@philipp-gruppe.de

PHILIPP VERTRIEBS GMBH

Pfaffing 36
5760 Saalfelden / Salzburg

☎ +43 6582 7 04 01

✉ info@philipp-gruppe.at

PHILIPP POLSKA SPÓŁKA Z O.O.

ul. Wojska Polskiego 1
47-220 Kędzierzyn-Koźle / Opole

☎ +48 503 353 816

✉ polska@philipp-gruppe.de



HEADQUARTERS Aschaffenburg



Visit us!

www.philipp-group.com